

# BIOGAS DRYER



**Solution for  
biogas market**

Condensation of the water vapor in the gas is caused by temperature reduction which in turn results in a dehumidification. The condensate is separated out at KOD installed after the heat exchanger

[www.climateenergy.net](http://www.climateenergy.net)

Converting biogas (landfill gas and sewage gas) into electricity, constant gas quality is vital in enabling engines and micro-gas turbines to operate economically and efficiently. Contamination, in the form of solid particulate contained in the gas-stream must be separated out and the remaining moisture content reduced.

Advantages through gas cooling/drying

- Increasing the useable energy of biogas
- Protecting engines and plant technology from corrosion and wear and tear
- Longer service life of engine oils and spark plugs

By applying biogas dryer, we are offering you a solution which you are able to reduce repair and maintenance costs.

Our in house designed dryer/dehumidifier, BD series, is an ideal solution to remove harmful water vapor to improve the combustible quality. Product features SS316 heat exchanger tubes and SS304 moisture separator and modular construction for ease of servicing. All of the system components and piping is skid mounted for easy transport and installation.

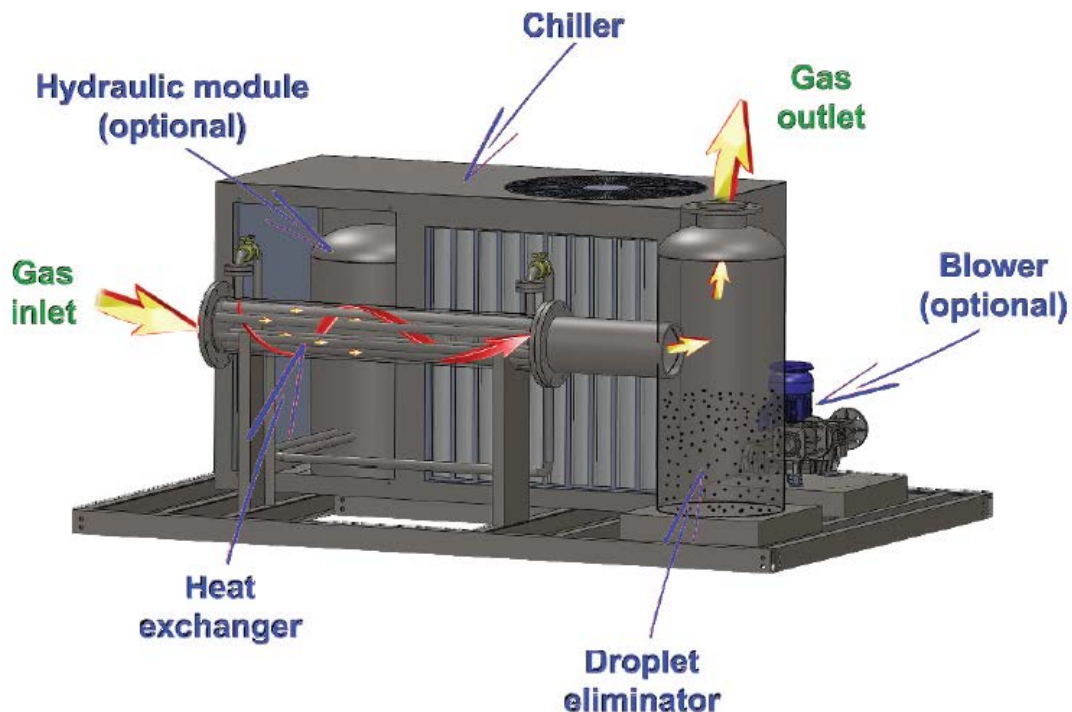



## Operation

After scrubber, treated wet biogas enters corrugated shell and tube heat exchanger. With biogas at tube and water glycol mixture at shell passing in counter flow, biogas is chilled to a dew point of 9°C. Chilled biogas will enter knock out drum (KOD) together with condensate. KOD with demister will removes all residual condensate created

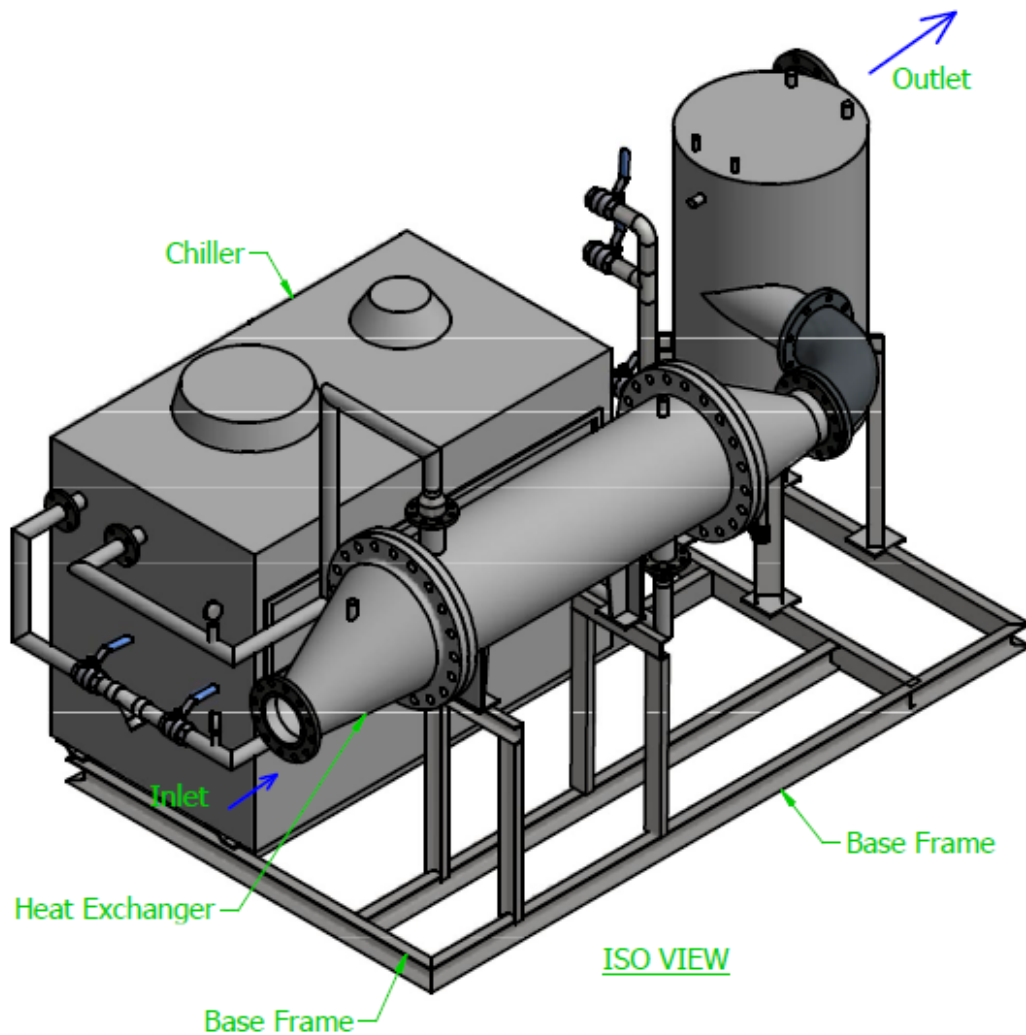

BD series configuration

## Construction

The dryer uses an air cooler and watercooled heat exchanger water / biogas. The two components are connected by a water recirculation loop Glycol. Knock out drum/separator and heat exchanger are made in Stainless steel 304, the skid is made in galvanised steel.



OPTIONAL:

- Skid made in Stainless steel
- Blower at dryer skid

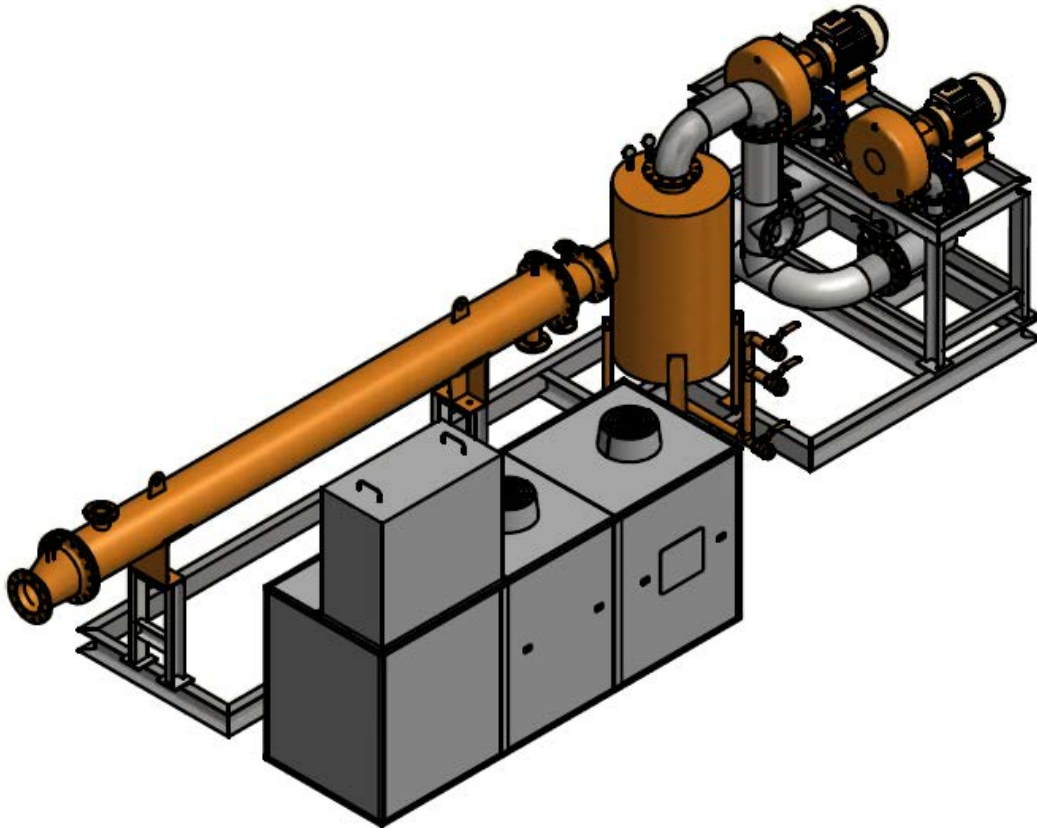

BD series with blower skid

## Features

- Compact packaged design mounted on an easy to install frame.
- Designed for external installation.
- Plug and play, arrives ready to operate
- Easy maintenance, wetted parts entirely in stainless steel
- High efficiency stainless steel demister at KOD
- Automatic condensate drainage
- Insulated heat exchangers for maximum system efficiency.

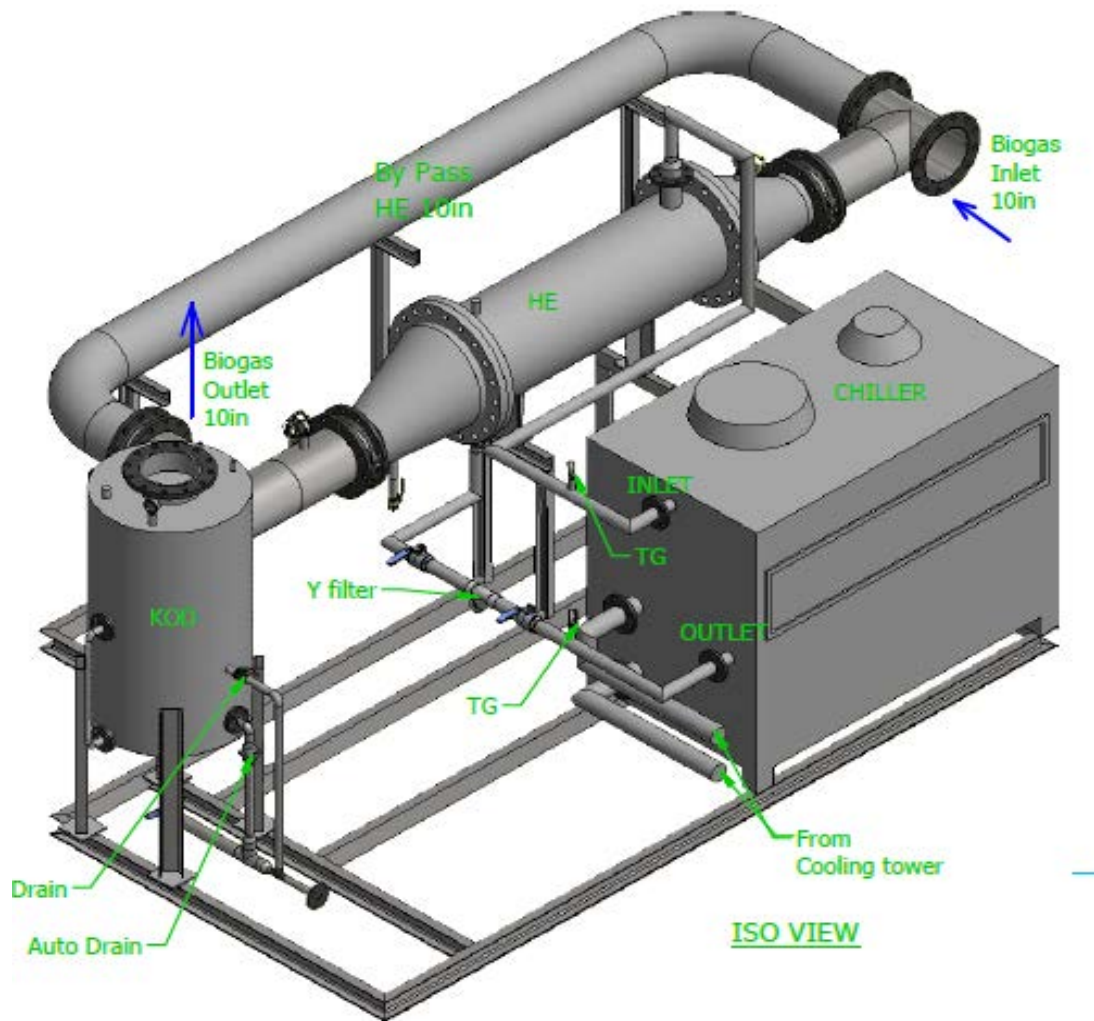

BD series with bypass line

## Benefits

- Improved CHP motor and gas turbine performance, with enhanced efficiency and reduced gas utilisation.
- Increased CHP motor-oil longevity.
- No condensate formation in the gas lines.
- Eliminates corrosion problems created by the combination of condensate, carbon dioxide and hydro sulphuric acid.
- Reduced system down-times and lower maintenance costs.
- Supplies dry gas to the activated carbon tower, thereby improving its performance and longevity

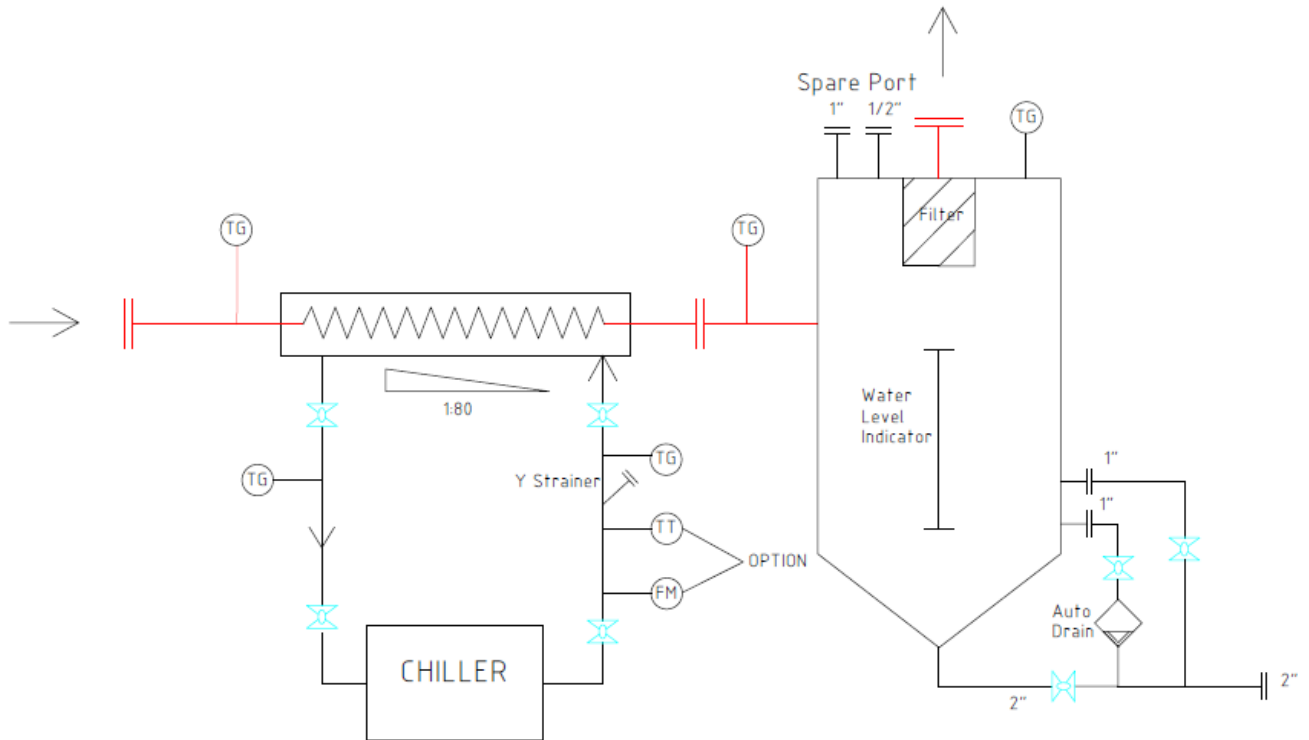

BD series P&ID

Range of BD series

Model	BD400	BD700	BD1200	BD1500
Flow rate m <sup>3</sup> /hr	400	700	1,200	1,500
Mass flow rate	460	805	1,380	1,725
Heat Load, Kcal/hr	18,000	33,000	60,000	75,000
Condensate removal, Kg/hr	20	30	50	60
Chiller power consumption, Kw	7.5	11	22	30
Running amp, A	18	26	52	70
Type of compressor	Reciprocating Hermetic, 1 duty, 1 standby			
Type of evaporator	Submerged cooling coil at insulated FRP tank			
Temp in / Temp out, Celsius	4 / 7			